

THE

May 2016

UTILITYSOURCE

Products and Services for Today's Electric, Telecom, and CATV Utilities

**New LineWise "Hydraulic" Phase Lifter
Safely Increases Productivity of
Raising Energized Lines**

Legacy of Success
Time Versalift



GPS INSIGHT FLEET & ASSET TRACKING SOLUTION



Your helping hand in fleet management

The Premier
TRACKING SOFTWARE FOR YOUR FLEET



866-477-4321

gpsinsight.com



EUFMC SHOWCASE

The world leader in aerial lift production for over 30 years, Versalift is dedicated to developing innovative solutions that meet the ever-changing needs of aerial industries. Last year, we introduced the subing-edge Phoenix 180-1 and Skybird 215-1 transmission lifts to our already impressive fleet. The 907-7100-HD and Digger Derrick T & B series add to the diverse capabilities that Time Manufacturing has always been known for.

VERSALIFT
PHX

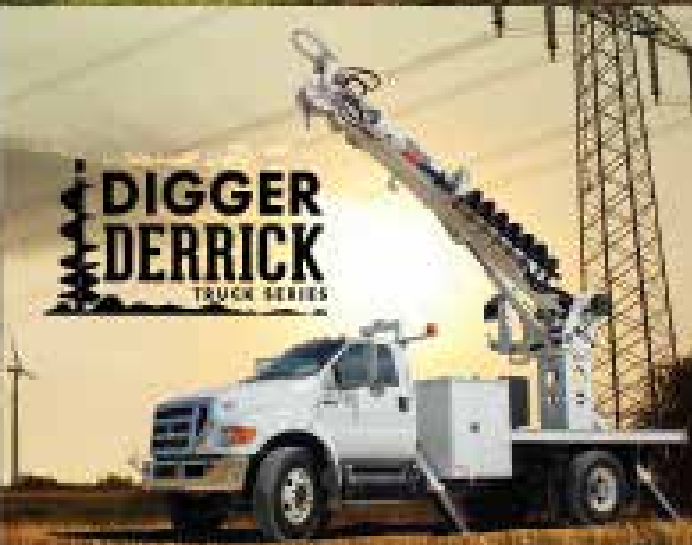

PG 6	Industry News
PG 12	New LineWise "Hydraulic" Phase Lifter Safely Increases Productivity of Raising Energized Lines
PG 16	The Power Gripz High-Voltage & Low-Voltage Leather Protectors & Work Gloves
PG 20	NoteVault & Cat Phones Partner to Equip Mobile Workforce with Productivity Enhancing Tools
PG 24	Company Profile: Legacy of Success-Time Versalift
PG 28	Terex Texoma Spiral Bullet Tooth Auger Offers Cutting- Edge Productivity
PG 34	New Product News
PG 40	Ad Index

ASSOCIATE GROUP PUBLISHER	Rick Harless 205-624-3794 rick@handfmedia.net
EDITOR	Annie McGilvray annie@handfmedia.net
CREATIVE/WEB DIRECTOR	Jacklyn Greenhill jacklyn@handfmedia.net
ADMINISTRATIVE DIRECTOR	Steven Hobson steven@handfmedia.net

CEO
Christy Hobson

PRESIDENT
Glen Hobson



Executive and Advertising Offices

PO Box 1568
Pelham, AL 35124

phone: 205-441-5591 fax: 205-624-3354

www.theutilitysource.net
glen@handfmedia.net

The Utility Source™ is published twelve times a year on a monthly basis by H&F Media Group, Inc. The Utility Source™ is distributed free to qualified subscribers. Non-qualified subscription rates are \$57.00 per year in the U.S. and Canada and \$84.00 per year for foreign subscribers (surface mail). U.S. Postage paid at Birmingham, Alabama and additional mailing offices.

The Utility Source™ is distributed to Power, Telcom and CATV Utilities and Utility Contractors throughout the USA. Publisher is not liable for all content (including editorial and illustrations provided by advertisers) of advertisements published and does not accept responsibility for any claims made against the publisher. It is the advertiser's or agency's responsibility to obtain appropriate releases on any item or individuals pictured in an advertisement. Reproduction of this magazine in whole or in part is prohibited without prior written permission from the publisher.

POSTMASTER: Send address changes to
H&F Media Group, Inc., P.O. Box 1568
Pelham, AL 35124
PRINTED IN THE USA

Get Cool!



Extend transformer life!

Increase transformer capacity up to 166%!

- expert technical assistance
- low sound levels
- energy-efficient motors
- large inventory
- one-piece cast aluminum blades
- galvanized or stainless steel guards



quality engineered, performance tested

Rugged Dependability

STANDARD IN EVERY MACHINE WE BUILD!

Hogg & Davis has been proudly manufacturing utility line equipment for more than half a century.



Our trusted products are part of the fleets and tool cribs of nearly every investor-owned power and communications company in the United States and Beyond.



HOGG & DAVIS, Inc.

HOGG & DAVIS, Inc.

3800 EAGLE LOOP • EDELL, OR 97044

TEL 541.854.1001 • FAX 541.854.1080

WWW.HOGGDAVIS.COM

Shawmut Equipment Company

Utility Equipment Rentals, Sales, Parts and Service

Why Shawmut Equipment?

Reliable Equipment

Shawmut Equipment only carries the finest brands available. We have developed strong relationships with the manufacturers we represent, allowing us to satisfy all of your equipment needs.

Knowledgeable Technicians

Our service department is staffed with technicians who undergo constant training to learn about the latest innovations in technology in order to support, service and maintain your equipment quickly and correctly. We provide our technicians with a fleet of service trucks equipped to make fast, on-site repairs 24 hours a day. Our facilities are equipped with state-of-the-art diagnostic tools.

Parts Availability

Our Parts Department at Shawmut Equipment is one of the best in the nation, and Shawmut's team of Parts Sales Representatives have the talent, knowledge, and experience to get equipment users the right parts quickly.



New National NBT45-TU Tracked Crane Now Available

Shawmut is excited to now offer sales and rentals of the new National NBT45-TU, a 45 ton capacity hydraulic crane, mounted on a Prinoth Go-Tract 4500 rubber tracked carrier. The new National NBT45-TU is designed to combine the strong capacity chart and high reach of the National NBT45 with the low ground-bearing pressure of the Prinoth GT4500.

The National NBT45-TU is equipped with a 142 ft five section full power main boom and 55 ft extension, for a maximum tip height of 203 ft. The Prinoth carrier is outfitted using the developed sprocket-track system allowing for superior stability.



Call Shawmut's Sales Department at 508-238-1900 for more information.



Shawmut Equipment

Serving the Equipment Industry Since 1957

(508) 238 - 1900

SALES • RENTALS • PARTS • SERVICE



Tracked Buckets



Tracked Digger Derricks



Tracked Cranes



Tele-Boom Crawler Cranes



Boom Trucks



Industrial Cranes



Rough Terrain Cranes



Rubber Track Carriers

Shawmut Offers:

- Superior Customer Service
- Three Full Service Facilities
- Factory Trained Technicians
- 24 - Hour On Site Service
- Latest Diagnostic Equipment
- Extensive Parts Inventory

CONNECTICUT

20 Tolland Turnpike
Manchester, CT 06042
Toll Free: (800) 829-4161
Office: (860) 643-4161

MASSACHUSETTS

136 Eastman Street
South Easton, MA 02375
Toll Free: (877) 526-9213
Office: (508) 238-1900

NEW BRUNSWICK

327 King William Road
Saint John, NB E2M 7C9
Toll Free: (888) 594-8444
Office: (506) 635-1550

www.shawmutequipment.com

Crane Tech LLC Lifting Operation Supervisors Program

Crane Tech LLC, the industry pioneer in crane safety and training for the materials handling and construction industries, is pleased to announce the launch of a new program for lifting operation supervisors.

Crane Tech has found that supervisors put in a position to oversee lifting operations often don't have the background or training necessary to recognize crane and rigging hazards or fully control lifting operations and safety. This leaves workers exposed to hazards that a more experienced supervisor can properly mitigate. The new Mobile Crane Safety for Managers program addresses operator and management responsibilities and key concerns. Topics will address a practical application of crane regulations, factors that influence safe and unsafe operations, how to read and interpret load rating charts, inspection requirements, evaluating site conditions, proper crane set up, power line safety and lift planning.

This one-day course was created to maximize the time of busy professionals while providing a high-level overview in the areas where Crane Tech typically finds opportunities for improvement.

www.cranetech.com

Matthew Wilson Named 52nd President of NTEA



Matthew Wilson, chairman & CEO of Switch-N-Go, AmeriDeck & Bucks Divisions of Deist Industries Inc. (Hadley, Pennsylvania), was installed today as 52nd president of NTEA – The Association for the Work Truck Industry. He accepted this position from immediate past president Jeffrey Messer, president of Messer Truck Equipment (Westbrook, Maine), at the President's Breakfast and NTEA Annual Meeting held in conjunction with The Work Truck Show® 2016.

"The time I've spent on NTEA's Board of Trustees has been invaluable," said Matt. "I'm excited to take on the role of Association president and focus on continued development of our offerings to the membership and industry in the coming year."

Matt joined Deist Industries in 2006 as a division manager, becoming general manager three years later. In 2010, he was appointed president, and, later that same year, he and his wife acquired full ownership of the business. He maintained the position of president until 2015 when he transitioned to his current role as chairman & CEO.

www.ntea.com/worktruckshow/

Weather Resistant Solid Brass Padlocks
Made to your specifications in the U.S.A.

HERCULOX
Hercules Industries, U.S.A.

HERCULES INDUSTRIES, INC.
 Manufacturer of HERCULOX Padlocks
 P.O. Box 197 • Prospect, Ohio 43342
 Toll Free: 1-800-345-2590
 Fax: (740) 494-2274
www.HERCULOX.com

Crane Tech LLC Lifting Operation Supervisors Program

Terex names new branch managers to oversee its Service Center operations. Jeremy Dehnel joins the Terex team as Branch Manager in the Waukesha, Wis., location, and Chad Rudebusch takes over as Branch Manager in the Watertown, S.D., location. As Branch Managers, Dehnel and Rudebusch will support all Terex Utilities products and services to a wide-range of customers, including investor-owned utilities, electric cooperatives, municipalities and utility contractors.



"Both Jeremy and Chad bring unique skill sets and experiences to the Branch Manager role," says Terex Director of Operations, Richard Gunderman. "As we continue to develop innovative product offerings, services and programs to meet the growing needs of utility customers, Jeremy and Chad will both play an extremely important role in growing our opportunities in the marketplace."



www.terex.com/utilities



**LARSON
ELECTRONICS**

Fully covered.

No one thinks about hazardous area lighting more than Larson Electronics. That's why we carry a complete lineup of gear for workers to keep them safe in challenging conditions.

Our line of LED light towers and diesel-powered generator light towers that provide safety and visibility even during the darkest of hours. Our LED explosion proof floodlights are low heat, high powered and available in hazardous areas for maximum work areas.

Whether it's routine maintenance or a citywide power outage, Larson Electronics provides the lighting solutions that keep your crews safe and focused.

Contact today at 1-800-387-5641 or email sales@larsonelectronics.com to discuss meet your hazardous location lighting needs.

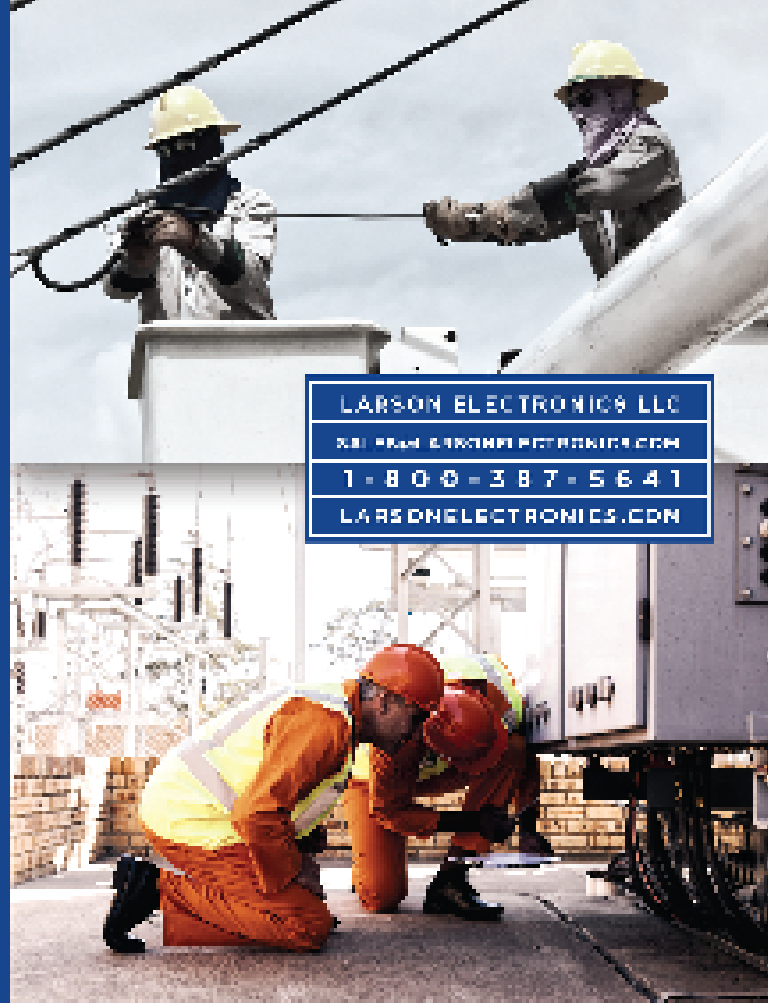

LARSON ELECTRONICS LLC

231 PARK STREET ELECTRONICS.COM

1-800-387-5641

LARSONELECTRONICS.COM



**Mini LED Light Tower with 5000W Generator
Two 400 Watt LED Lamps
Part # WLT-LED-5000-02TL-LED-03**

**Mini Portable LED
1000 Watt LED
Part # CABLE-01**



**Portable LED Tower with
Diesel Engine Generator
4 1000 Watt LED
Hazardous
Part # WLT-0400-04TL-LED-01**



WE HAVE THE ROPE TO GET THE JOB DONE.



800-358-767

www.bucrope.com

TUS INDUSTRY NEWS

Utility One Source Now Renting Ring-O-Matic



Owning and renting Ring-O-Matic vacuum-jetting rigs is now easier than ever through a new agreement with Utility One Source. Utility One Source, which provides complete sales, rental and aftermarket services including remanufacturing and customization of industry-leading heavy-equipment brands, will now make the vacuum-jetter rigs available to customers nationwide from its 23 locations.

Brian Metcalf, Ring-O-Matic CEO, said, "We are very pleased to have a partner who is as dedicated to its customers' success as we are ourselves. It truly is a perfect fit, giving customers convenient access to our full line of vacuum excavators throughout North America, with the backing and expertise of Utility One Source."

Ring-O-Matic's high cfm 550- and 850-gallon VacEx vacuum excavators and patented Viper potholing tool are available in trailer- and truck-mount versions.

Ring-O-Matic is a manufacturer of vacuum and vacuum-excavator systems, as well as carwash pit cleaners. Tank capacities range from 150 gal. (600 L) to 3,000 gal. (11,500 L).

www.ring-o-matic.com

Ranger Design Awarded at The Work Truck Show 2016

The Work Truck Show® 2016 Innovation Award was presented last week to Ranger Design (Ontario, New York) for the company's Max View safety partition. Ranger Design received the award at The Work Truck Show 2016, held March 1-4 at the Indiana Convention Center in Indianapolis, Indiana.

The Work Truck Show Innovation Award goes to the product at the Show deemed "most innovative" by a panel of trade media editors and truck fleet managers. All products entered in The Work Truck Show 2016 New Product Spotlight or New Product Media Guide programs are eligible.

Max View is a safety partition with a top portion molded out of clear thermoformed ABS and polycarbonate to snugly fit Ford® Transit Connect, Ram ProMaster City® and Mercedes-Benz Metris cargo vans. The Max View partition's see-through feature greatly enhances cargo space visibility, reduces blind spots, permits more light into the cab and creates the feeling of a more wide open, less claustrophobic cab space, according to the company.

www.rangerdesign.com

THE TOOLS YOU TRUST

HASTINGS

When it comes to safe, dependable hot line tools and equipment – we've been getting you home safely since 1959.

Test hot sticks wet or dry with the Hastings' Hot Stick Tester. Line men can determine leakage current in microamps with this portable, lightweight, and easy-to-use tool.

See page 501 of Hastings' online catalog for more details!



HASTINGS
A WORLDWIDE SUPPLIER OF
Hot Line Tools & Equipment

See our online catalog at:
hfcp.com • 269.945.9541

Designed to meet your underground cable pulling needs



UP-120-80H
Underground Puller



UP-70-16D
Underground Puller



UP-85-8D
Underground Puller



S660 Sewer Rodder



CP9800 Articulated Boom Puller

Exclusive US Supplier



www.tse-international.com



TIMBERLAND
EQUIPMENT SOLUTIONS GROUP

NEW FOR 2016



Venturo Van Crane

With the increased demand of work vans in the industry, Venco Venturo has developed a *small crane* application that will increase productivity at any job site. Designed for use within the rear cargo area, the new van crane from Venturo will retain the rugged designs that have set the standard of our cranes for generations.

To learn more, visit www.venturo.com.



TRUCK-MOUNTED CRANES, CRANE BODIES & HOISTS



VENCO VENTURO INDUSTRIES LLC

12110 BEST PLACE | CINCINNATI, OHIO 45241

800-226-2238 | info@venturo.com | www.venturo.com



New LineWise “Hydraulic” Phase Lifter Safely Increases Productivity of Raising Energized Lines

LineWise introduces its latest breakthrough in utility line equipment, the Hydraulic Phase Lifter, a patent-pending insulated crane attachment that can safely support up to three energized lines at once.

The versatile Phase Lifter allows workers to come in from underneath and hold the conductor, as opposed to over the top with rigging sticks hanging from a crane. This provides a significant advantage in areas where there isn't enough overhead clearance to get outside and above the conductor.

The Phase Lifter also has an impressive 1,500-pound total vertical load and 225-pound side load capacity per conductor. Maximum conductor spacing is 14.5 feet in increments of 6 inches, for a maximum width of 29 feet, which is particularly appealing to large, high-voltage operations.

Because safety is always a concern when dealing with energized lines, the quick-attach insulator is available in industry-standard “Line Post Polymer” or “Sealed Fiberglass”. The arms are sealed fiberglass and include a desiccant canister to absorb moisture and add another layer of protection. Furthermore, the quick-attach insulator requires no tools to install or remove, maximizing simplicity.

To attach the Hydraulic Phase Lifter to a crane, an adapter specific to the type of crane is fitted. A hydraulic cylinder changes the angle of the Phase Lifter. The crane's boom is

angled from 55- to 80-degrees for horizontal and vertical builds. The hydraulic power source for the hydraulic cylinder is provided by a self-contained hydraulic power unit (HPU) on the Phase Lifter or from the crane.

When it comes time for setup, the Phase Lifter's exclusive folding arms are mechanically synchronized to open and close simultaneously. A pin automatically slides into a slot to lock the arms in a working/open position, while a cross pin locks the pin in place. The arms lock together when closed, and the Phase Lifter stows on the side of the crane for easy transport to and from a jobsite.

If you are planning on attending the ICUEE show LineWise will have a NEW Hydraulic Phase Lifter and a NEW Hydraulic Insulated Work Platform mounted to Manitex cranes in Booth#N2019. Also, please stop by our indoor Booth#2452 to see the newest LineWise Utility Products.

LineWise is a division of Diversified Products. The company designs, engineers and manufactures a full line of utility products, including line lifters, insulated work platforms, phase lifters, transmission temporary conductor supports and the Buddy Bushing cross arm reinforcement system. For more information, contact Diversified Product Development, 1001 Webster Avenue, Waco, Texas 76706, phone 254-757-1177, or visit the website at www.diversifiedproduct.com.





ClearSpan fabric structures

1.866.643.1010 ClearSpan.com/ADNCP

WE MANUFACTURE - WE INSTALL WE SAVE YOU MONEY

VERSATILE SOLUTIONS FOR ALL YOUR CONSTRUCTION NEEDS



Fabric Structures
Natural Light & Low Cost Per Sq Ft

Hybrid Buildings
Benefits of Metal & Fabric Buildings

Foundation Solutions
Build Anywhere & Quick Construction

GET **0%** FINANCING FOR **84** MONTHS OR GET A **BIG CASH** DISCOUNT *RESTRICTIONS APPLY

**CAN ONE HITCH TAKE CARE
OF ALL YOUR TOWING NEEDS?**



TOWING MADE EASY

Available in Class IV & V with 10K, 16K & 21K lb. weight capacities. Safely and efficiently move any trailer without having to swap out hitches.

GEN-Y HITCH
BY GENY INDUSTRIES

574-218-6363

www.GenyHitch.com

Made in the USA

The Power Gripz High-Voltage and Low-Voltage Leather Protectors and Work Gloves

The Power Gripz, designed by linemen for linemen, are the only high-voltage and low-voltage leather protector gloves tested and proven by science to be superior for grip, arc protection, heat penetration and all weather dexterity. Proprietary grip pads (patent pending) provide unparalleled gripping power without compromising hand dexterity and safety in all weather conditions.

- Highest ATPV Rating in the industry: 40cal/CM2.
- Blocks fully 94% of heat penetration in EBT testing
- Meets and/or exceeds all ASTM F-696 Standards for leather protector glove design

In addition to high voltage and low-voltage leather protectors, The Power Gripz also offer a full line of work gloves styles including Unlined, Thinsulate® lined and Kevlar® (category A4 cut-resistant) lined. High and low-voltage sizes 8-12.5, Three-finger mitt sizes 9-11 and work gloves in M, L, XL, XXL

Brand new and already taking center stage is THE POWER GRIPZ40cal Leather Utility Work Glove that is Fire, Water AND cut Resistant. This sturdy, good for about everything work glove, deserves a full



introduction: water-resistant, insulated work glove that is Arc Rated, Cut Resistant, Flame Resistant and Water Resistant. Made of high-quality cow skin leather it is a category A4 CUT RESISTANT GLOVE. The proprietary POWER GRIPZ grip pads reinforcement on the fingertips, and palm enhance the durability and protection while maintaining high dexterity. Arc Rated. Flame Resistant. Cut Resistant (A4). Water-resistant. Insulated.40cal/CM2.

THE POWER GRIPZ has you covered when it comes to work gloves- there is something for every preference. Lineman need and deserve a better grip on the tools and small parts, as well as all other equipment they use. Test a pair of Power Gripz for yourself and see why The Power Gripz are quickly becoming the leather protector of choice for utilities and power linemen everywhere!

For more information call 877-271-0444.

www.thepowergripz.com



**american
pipe &
plastics Inc.**

PART OF **atkore**
INTERNATIONAL



AMDUCT POWER, COMMUNICATIONS AND ELECTRICAL CONDUIT

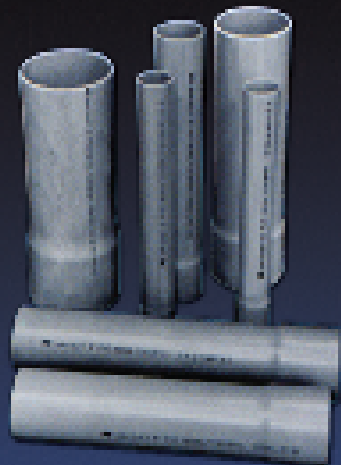

- Manufactured to meet NEMA TC2, NEMA TC6/8, ASTM F512 and UL651.
- Sweeps, bends, and fittings are manufactured to meet NEMA TC3, NEMA TC9 and UL651.
- Our PVC Conduit has a smooth bore that reduces cable drag.
- Lightweight, flexible, easy to handle and resistant to impact.
- The solvent welded joints ensure water tight integrity excellent resistance to chemicals, rot, rust and electrolytic corrosion.

www.ampipe.com – (607) 775-4340

Shoo-pin™

Flex-Cable Adapters

PT-FX Series adapters are designed to terminate high-strand flex-cable (locomotive, mining, welding) to machinery, panels, and transformers. The pins fit mechanical set-screw type connectors and are sized for the current carrying capacity of the cable. These adapters feature the Greaves flared Shoo-in™ barrel-opening design for easy cable insertion. Insulating covers are provided.

Wherever flex-cable terminates in a set-screw lug:

- Telecommunications
- Construction Sites
- Drilling Platforms
- Theme Parks
- Locomotive
- Welding
- Marine
- Mining



GREAVES

www.greaves-usa.com

800-243-1130

Go Green and Dramatically Reduce Fuel Cost!

The patented ICOM JTG II Liquid Propane System
is innovative and offers these advantages:

- Nationwide Installation & Service
- Equal power, torque and drivability of gasoline
- Cold climate reliability
- Reduces greenhouse gas emissions by up to 20%
- Dramatically reduced emissions
- Virtually no particulates
- Fuel range extended with the use of bi-fuel
- Extended service intervals



ICOM's Propane Optimization
Program' (POP) eliminates driver
input to maximize propane usage

ICOM NORTH
AMERICA
Alternative Fuel Systems

NoteVault and Cat Phones Partner to Equip Mobile Workforce with Productivity Enhancing Tools

Free NoteVault for four months with every purchase of a Cat® smartphone.

NoteVault, a leading provider of mobile reporting solutions have teamed up with Cat phones to serve the growing segment of the mobile workforce who are looking to increase their productivity by combining rugged smartphones and mobile technology. Launching their Smart Tools for Smart People campaign, all purchases of Cat smartphones from catphones.com will qualify for four months of a NoteVault Premium account, worth \$396, totally free of charge for a limited time only.

“When facing the day to day challenges of working on a construction site we refuse to believe that being rugged means you have to make a compromise. Cat smartphones bring together powerful performance with industry leading tough credentials,” said Peter Stephens, CEO of Bullitt Group, the global licensee of phones and accessories for Caterpillar Inc. “By offering an industry-dedicated app store, including on-site reporting apps like NoteVault, we ensure that our customers are fully equipped when on site with the tools needed to get the job done.”

CCS Insight forecast that in 2016, 18.4 million rugged smartphones will be shipped worldwide. These devices are similar in design and user experience to the consumer-grade smartphone, but offer enterprise-grade levels of ruggedness and additional features for those working in demanding environments, e.g. improved daylight readability and the ability to use the device whilst wearing gloves.

Ken May, Chief Commercial Officer for NoteVault explains, “The NoteVault platform is used by many of the world’s top construction and engineering firms. Much of their workforce operate outdoors where water and dirt impede their ability to use their mobile device and NoteVault apps. Having a rugged Cat smartphone running NoteVault will enable them to keep delivering daily reports. We’re excited to team up with Cat phones to offer our customers a smartphone designed for the environment where they work.”

Through the Smart Tools for Smart People campaign, Cat phones will provide a voucher for four free months of a NoteVault Premium account, for more information visit www.notevault.com/cat

The NoteVault Premium Account includes:

- NoteVault Daily Reporting Platform
- Notes! app for Android or iOS
- Activities crew app for Android or iOS
- Unlimited human transcription
- Immediate notification of incidents through keyword notification
- Collaboration with colleagues

www.notevault.com/cat



Protect yourself from "Arc Flash"



ARC FLASH HOOD WITH V¹² HIGH-VOLUME VENTILATOR Compact. Powerful. Reliable

Our V¹² High-Volume Ventilator boasts an unexpectedly quiet, high output (35+ CFM) turbine fan to cool and circulate the ambient air within the hood. Fully protected beneath it's durable ABS shell and added fabric layering, the V¹² High-Volume Ventilator isn't just compliant, it's superior.



40 CAL/CM2 ULTRALIGHT CLOTHING BY OTEX

Our new dual-layer Ultralight clothing takes advantage of DuPont's® dedication to scientific advancement and Westex's® industry leading dependability. Weighing in 37% lighter than traditional HRC4 PPE, our Ultralight Clothing is the most innovative contender in the lightweight arena.

HYBRID LAYERING

Combined Fabric Weight: 14 oz

Outer Layer: DuPont® Protera
Color: Navy

Inner Layer: Westex Ultrasoft
Color: Safety Orange

FOR FREE INFO, CIRCLE 20 ON READER SERVICE CARD

CALL US TODAY

(703) 367-0404

OR VISIT OUR ONLINE ELECTRICAL SAFETY EQUIPMENT STORE

www.millersafetyltd.com



**THE
POWER
GRIPZ**
Leather Protectors
.COM

Power
Gripz Inc.

*Designed by Linemen,
for Linemen.*

USA, complete covered
leathered and
leather protector
gripz.com

The Power Gripz are the only gloves
tested and proven to be superior
for grip, arm protection and
all-weather dexterity.

Patented all-weather
finger gripz and
leather protector
gripz.com

Patented leather
material and
leather protector
gripz.com

Reverse side
leather protector
gripz.com

Low and High Voltage
Finger Leather Protectors, available
in sizes: 8-8.5 through 12-12.5;
Three Finger Mitts sizes 9-11.
Three styles of work gloves, M, L and XL.

AT&T ratings: 300 volt and 1000 volt

Ultimate Protection. Maximum Comfort.

Tested by
ArcWear

Call: 877.271.0444
or order online at
www.ThePowerGripz.com

Deeper. Faster. Stronger.



Spiradrill hydraulic drilling rigs simply out perform the competition. With models reaching as deep as 100 feet and hole diameters up to 12 feet, Spiradrills bury other rigs. Efficient designs minimize setup time and truck-mounted rigs arrive on-site, ready to dig in. Ring Power offers the Spiradrill family on crawlers or trucks, with low clearance and EZ Trac options available.



Ring Power Utility Equipment has Spiradrills available today.



Nationwide Rental and Sales through



Utility.RingPower.com

Contact Josh Ratcliff • O: 904-255-1763 • C: 904-401-2683 • Josh.Ratcliff@RingPower.com

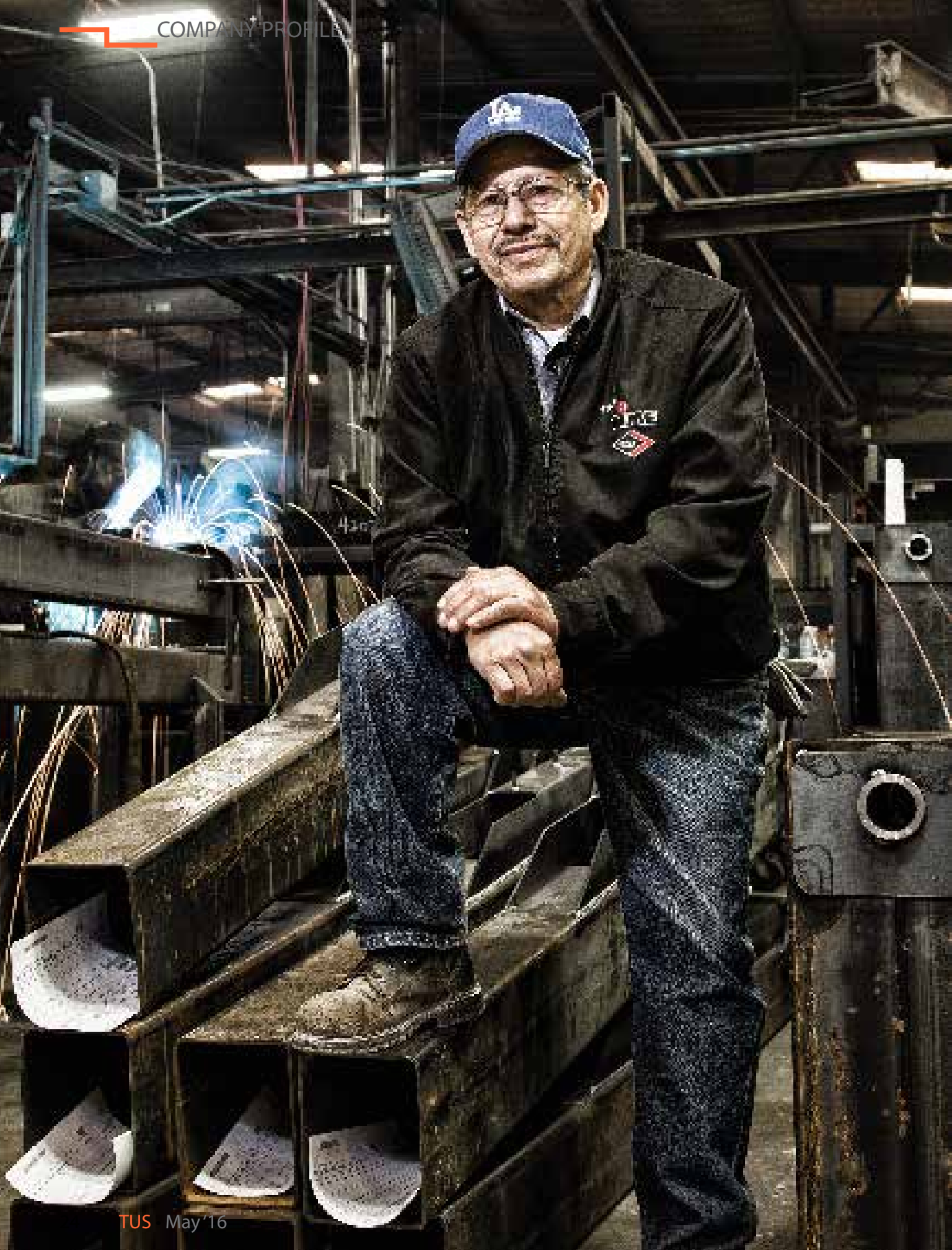

Legacy of Success

Humble Beginnings

In the mid '60s the telecommunications industry was rapidly expanding. Most homes were equipped with telephones and although cable television was in its infancy, interest in this new media platform was growing. As these two technologies developed at an unprecedented rate, local telephone and fledgling cable companies searched for ways to increase their efficiency while providing a safe working environment for their employees.

In 1965 linemen were required to climb poles which was dangerous and physically demanding, particularly to the older employees. Developed in the small Central Texas town of Clifton, Texas by Russell Howard, a mechanical engineer, and Charles Turner, whose family owned an independent telephone company in Palo Pinto County, Texas, TIME MANUFACTURING COMPANY was 'born out of the need' to provide 'Time Saving Equipment' that was maneuverable, safe and a dependable way for telephone linemen to perform tasks at varying heights above ground. The current Waco, Texas location, home to Time Manufacturing, was built in 1972. Today, with two state-of-the-art manufacturing facilities and over 300,000 square feet under one roof, Time is one of the leading premier facilities of its kind.

Aerial lift orders rapidly increased with VERSALIFT's first large sale of multiple units to a Michigan-based telephone company. In the late 70s, the company's customer base stretched globally as we introduced our product to the European market. Product lines, sales, and customer relationships continued to grow, and in 1985, Time Export was established in Farso, Denmark. In the 90s and 2000s, we made international strides with the establishment of VERSALIFT distributor locations in Europe, Africa, Middle and the Far East. Here in the U.S., we were

expanding as well with the addition of VERSALIFT East in Bethlehem, PA., VERSALIFT Southwest in Waco, TX., and VERSALIFT Northwest in Salem, OR.

Although Time Manufacturing is one of the foremost aerial lift manufacturers in the world, throughout the years we've not veered far from our modest, ambitious beginnings. We've grown in both employees and global reach, yet our belief is still the same as our founders: Solutions to your aerial lift needs should always be within the customer's reach.

Although Time Manufacturing is one of the foremost aerial lift manufacturers in the world, throughout the years we've not veered far from our modest, ambitious beginnings. We've grown in both employees and global reach, yet our belief is still the same as our founders: Solutions to your aerial lift needs should always be within the customer's reach.

History of Innovation

How do we keep your needs in mind while offering cutting-edge solutions? VERSALIFT innovations, such as the introduction of our patented TruGuard technology and incorporating the use of high-strength steel, were created with the success of your challenges in mind while pushing the limits of telescopic heights safety. Since the creation of our first aerial lift, Time Manufacturing has been committed to using the key components of technological innovation and customer feedback as a means to meeting customers' aerial lift needs. Even today, cofounder Russell Howard's dedication to his trade continues to inspire both our talented engineering department and experienced manufacturing personnel.

Each of Time Manufacturing's engineers begins their time at VERSALIFT learning the products by working side by side manufacturing. Once they understand the structural mechanics of our products from start to finish, their attention turns

to you. We dedicate time listening to customers explain their lift challenges in the field in order to design equipment specific to your needs. Collaboration with our customers while we build and test the new equipment also helps to ensure that your, as well as industry, safety needs are met while maintaining a standard level of productivity. Utilizing the exceptional skill base of our knowledgeable employees, our mission is to build VERSALIFT products designed to provide you with safe solutions and increase over customer satisfaction.

Future of Versalift

We're excited about what lies ahead for Time Manufacturing and our VERSALIFT product. Using our global manufacturing resources teamed with highly trained employees, the heights for the future are limitless. Time Manufacturing Company's stable ownership, consistent style of management and full production schedule also empower our plans for tomorrow.

Because we keep the customer in mind when planning for the future, VERSALIFT continues to extend fresh product offerings to our customer base, whether by implementing a rental and leasing fleet or cultivating our used equipment business. Though the VERSALIFT presence in our current industries is vast, we continue to look toward what's next, such as aerial lift needs in the emerging wind energy industry. New entry points for lifts in utility processes are also a priority, such as distribution, transmission, contracting, and more.

Look to VERSALIFT to be YOUR all-inclusive lift resource, where you can rent, buy, replace, and resell your lift or fleet of lifts with ease.

We're excited for the future of VERSALIFT. With our experience in growth, invaluable resources, and commitment to customer satisfaction, there's really only one way to go. And that's up!

Voted by Contractors As The Best Pulling Tools 2014

iTOOLCO



Made in the USA

Crank Lift and Bearing Spin
Real Jacks RJ6K

iTOOLCO

Huge Time Savings

PULLSLICK



Fastest When Pulled With the Cannon 10K

Cannon 10K Dual Capstan 4 Speed 10K Tugger "Easy, Strong, & Fast"

iTOOLCO

Demo Today

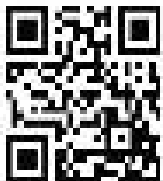

9 to 40 Fpm
Made in the USA

iToolco.com
865-670-3713

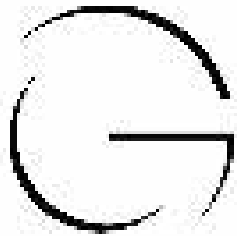

GOLIGHT

Revolutionary Lighting Solutions



Durable... Versatile... Powerful... GUARANTEED



When the job gets out of hand, we can rely on our ratings from it to show our clients and much in the elements to get our electrical service back online. More often than not, that means battling wind, rain, snow and ice and doing so in the dark. In those conditions, light that can be dramatically directed where it is needed, when it is needed is an essential tool for safety and productivity. In both emergency situations and day-to-day conditions, Golight has proven to be a vital tool in extending work hours and increasing productivity. Golight has been a partner to the men and women who keep our lights on for almost 20 years and we are committed to seeing that relationship grow and develop.



KOOLERS... BANDANNAS... DECALS... Send an email to media@golight.com and let us know you saw our ad in "THE UTILITIES SOURCE" and we will send you some Linean branded merchandise.

Terex® Texoma® Spiral Bullet Tooth Auger Offers Cutting-Edge Productivity

Performance-matched to the drill rig and
ground conditions for powerful production

For faster cycle times in and out of the hole in extreme ground conditions, the Terex® Texoma® spiral bullet tooth auger enables customers' drill rigs to achieve higher production drilling rates. The cut pattern and tooth attack angle on the Terex auger combine to make the bullet teeth act like "fingers" that penetrate through and lift up fractured or broken material. These Terex augers are effective in working in sand, dirt, cobble, cement, fractured or hard rock, compacted soil and frozen ground conditions.

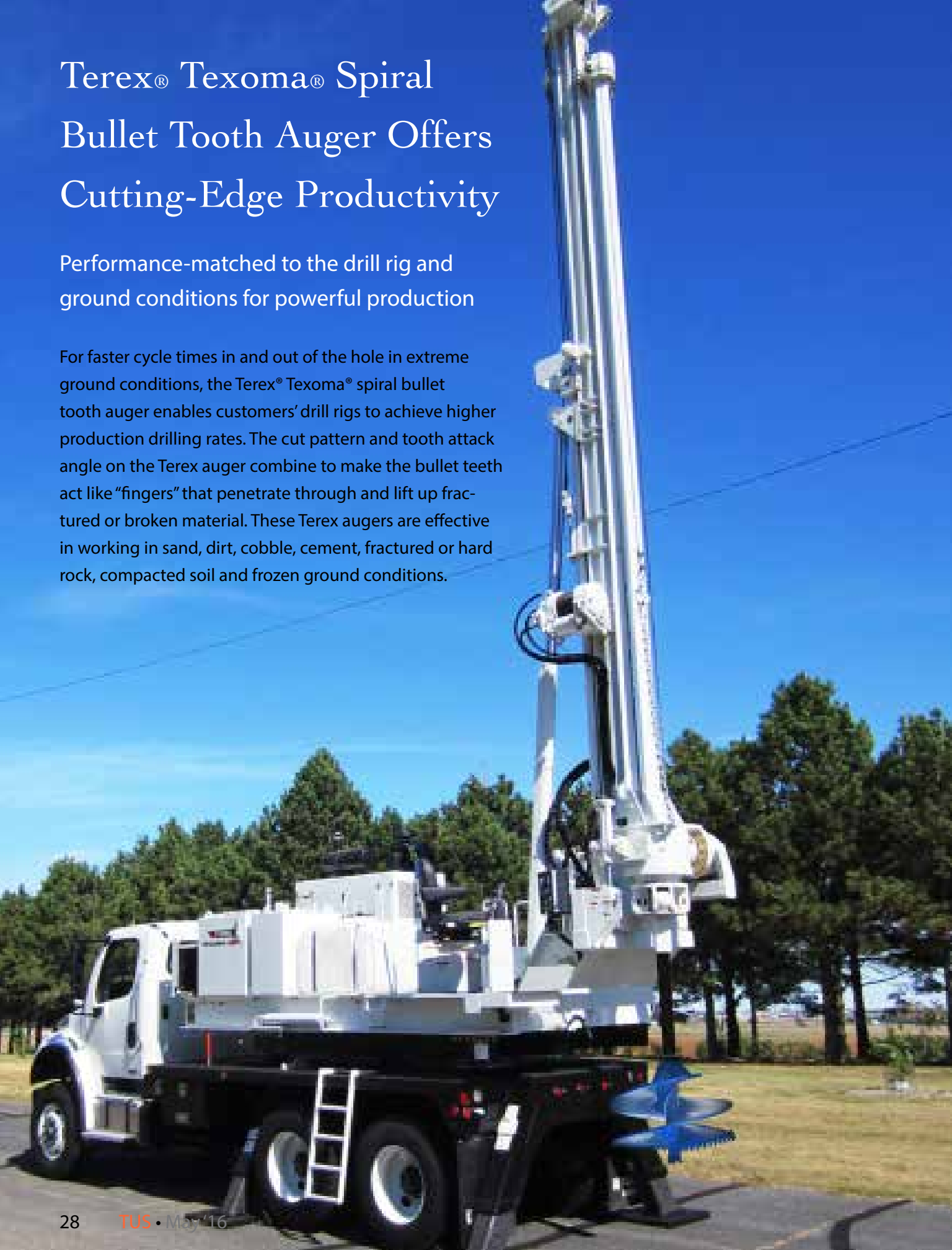

The SorbWeb™ Plus

Solution

OIL REACTIVE FABRIC

A Better Solution

Engineered Secondary Oil Containment System allows water to pass through but seals on contact with oil.

- Robust engineered solution
- Our Oilmat has the highest polymer loading in the industry with a minimum 2500 g/m² or 73.7 oz/yd²
- Installations follow a rigorous quality control protocol to ensure the containment is properly installed
- Designed to allow for vehicle access up to a max of 26,000 Kg/group of axle



1.866.269.8275 x 0235 | www.albarrie.com

According to Putnam, Terex has specially designed its spiral bullet tooth auger to allow each tooth to cut a small track which increases productivity. With its spiral-shape design and unique tooth pattern that distributes the cutting action evenly, this auger equalizes the work done by each

tooth on the cutting tool, increasing production rates and reducing tooth wear. "The efficiency and effectiveness of a contractor's drill rig is ultimately determined by the type of auger tooling used," says Dale Putnam, Terex Utilities product manager. "The auger tooling a contractor uses should be

performance-matched not only to the drill rig but also to the ground conditions the rig is operating in. Too often, contractors spend a lot of time and effort trying to push an inefficient auger tool into tough ground conditions, resulting in slow production rates and excessive wear and tear on the tool."

With a standard auger tool, says Putnam, one hole could take crews up to eight hours to drill. With the Terex Texoma auger, the same hole may only take them 30 minutes to complete. "And," says Putnam, "the Terex Texoma auger tool fits right on the existing drill rigs so contractors save



VAULT BLOWERS and ACCESSORIES

TRANSFORMER COOLING FANS and ACCESSORIES

CONFINED SPACE BLOWERS and ACCESSORIES

California Turbo, Inc.
(800)448-1446 fax: (909)854-2801
10721 Business Drive, Fontana, CA 92337
www.californiaturbo.com e-mail: hank@californiaturbo.com



money on equipment acquisition and utilization rates. Basically, if a contractor can get the auger drill to the jobsite, this auger tool can dig almost any hole. Even better, because this tool is designed for drilling in tough conditions it puts less strain on the equipment, which results in less downtime due to unscheduled maintenance and repairs.”

The Terex Texoma spiral bullet tooth auger can be used in virtually any ground condition, with all of the standard Terex tooth offerings, and is adaptable to any size of digger derrick truck. Terex offers a variety of flighting thickness and pitch options for this

auger, as well as custom specifications upon request to meet every customer’s particular drilling needs and conditions.

“Drilling contractors need to be able to tackle any ground condition with one machine,” finishes Putnam, “As productivity directly

correlates to profits, using the right tool maximizes both — auger tooling, engineered for high production drilling in virtually any ground condition, can dramatically improve a rig’s drilling performance.”

www.terex.com/utilities •



Aluminum storage equipment for Walk-in Vans, Service Bodies, Pickup Trucks and SUV's



**MAXIMUM EFFICIENCY
ENHANCED ORGANIZATION**

EZ STAK 550 Albion Ave. Schaumburg, IL 60193
630.994.3300 www.EZSTAK.com

ELECTRIC UTILITY FLEET MANAGERS CONFERENCE

SOLUTIONS FOR MANAGING A PROGRESSIVE FLEET

JUNE 5-8, 2016

WILLIAMSBURG LODGE
& CONFERENCE CENTER

WILLIAMSBURG, VIRGINIA

EUFMC

WILLIAMSBURG, VA

EST. 1963



Join **fleet professionals** from **investor-owned** electric utilities, electric cooperatives and electrical contractors from across the U.S. and Canada at the industry's premier educational event featuring:

- Presentations by industry experts, manufacturers and fleets
- Roundtables where fleet professionals and representatives from manufacturers and service providers share best practices
- A drive through utility equipment demonstration and an exhibition of the latest equipment and services for utility fleets

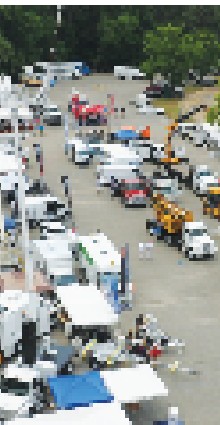

Dedicated to providing
educational value to
utility fleet professionals

REGISTER
TODAY!



757.220.1795

eufmc.com

Platinum Sponsors:



Attec

FREIGHTLINER

WORK SMART

BRIDGESTONE

DEEPO
U.S. FLEET CENTER

Telogis

ETI

FLORIAN & BRYAN

TEREX

**BUILT
TONGH**



PowerBully

Track Carriers

PowerBully track carriers.

Strong and rugged for challenging tasks.



PowerBully offers the perfect mobile base for digger derricks, cranes, man lifts, bucket booms and dump bodies.

- Versatility of application
- Fully rugged for the toughest tasks
- Test load capacities of up to 35,000 lbs
- Sensitive to the environment
- Low ground pressure
- Small footprint on the ground

BLUEIQ

Technology

www.powerbully.com

Smart Customer Mobile Launches Bill Savings Navigator

Smart Customer Mobile (SCM®), the award-winning, single integrated platform enabling utility companies to establish superior customer engagement, today announced the launch of SCM® Bill Savings Navigator. The new technology enables utilities to connect directly with income-qualifying customers and share information on cost-saving government-mandated efficiency and rebate programs.

Developed by Smart Utility Systems (SUS) -- a leading provider of cloud-based solutions focused on utility customer engagement and operational efficiency -- the easy-to-use app is the only utility customer engagement solution addressing the needs of both the consumer and utility, while providing a superior 360-degree customer experience.

According to the Bureau of Labor Statistics, there are some 40 million low to mid income households in the U.S. that are spending approximately \$70 billion every year on utilities alone. That reflects an expenditure of up to 14 percent of their total income, a percentage far greater than the average household, which spends just six percent, and high-income households, which only spend approximately three percent of their income on energy each year.

www.smartusys.com

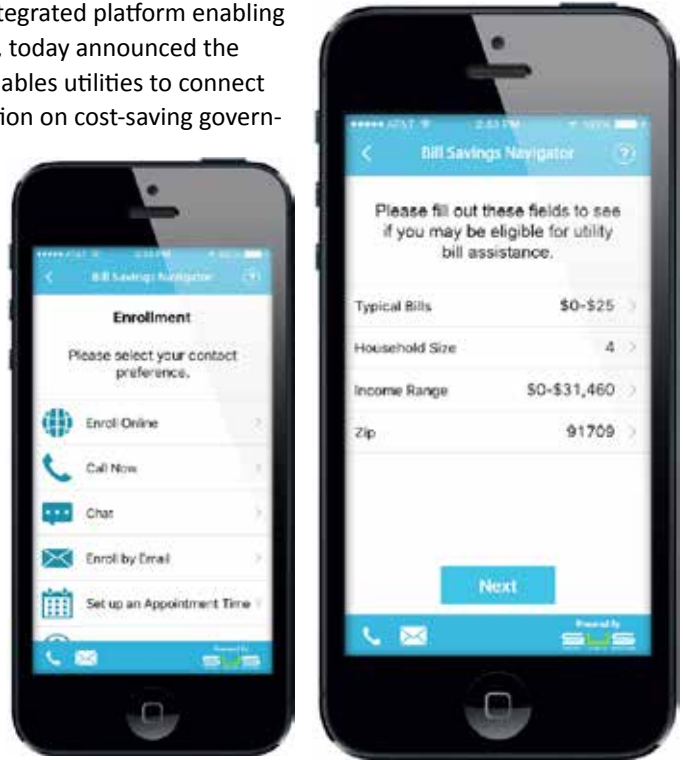

MOROOKA

SERVING THE UTILITY INDUSTRY NATIONWIDE

PRODUCT ATTACHMENT APPLICATIONS:

- Digger Derricks
- Field Service Equipment
- Telescopic Buckets
- Boom Cranes
- Personnel Carrier

MADE IN AMERICA

To locate a dealer near you, call 877-667-6652 or visit us at morookacarriers.com





LINE WARD CORPORATION



Built to efficiently bury or pull underground cables, pipe or fiber optics.

INFORMATION@LINEWARD.COM | 800-1-816-9621 | WWW.LINEWARD.COM

Optimize Fleet Productivity



CFA Software

FLEET MAINTENANCE & INVENTORY CONTROL SOFTWARE SOLUTIONS SINCE 1969

CFAWin

- ✓ Evaluate & Improve Fuel Economy
- ✓ Automate PM Tracking
- ✓ Increase Warranty Recovery
- ✓ Analyze Life-Cycle Costs & Trends

Why CFA Software?

- ◆ Over 40 Years Experience
- ◆ Superior Product Support
- ◆ Low TCO
- ◆ Free Implementation Assistance

Shop Floor

- ✓ Technician-Friendly Interface
- ✓ Allows RO Entry in Shop Environment
- ✓ Repair Time Clock Feature
- ✓ View Equipment Repair History

e-Service Request

- ✓ Submit & View Service Requests Online
- ✓ Provide Audit Trail of Submitted Requests
- ✓ Reduce & Automate Data Entry

Call for a **FREE Demo!**

CFA Software

800.437.6001 • www.CFASoftware.com

Elk River

Personal Fall Protection

P.O. Box 1770
Cullman, AL 35056-1770



800.633.3954

www.elkriver.com





DICA Patents SafetyTech Outrigger Pads

DICA has added a fourth patent to its SafetyTech® outrigger pads. The most recent U.S. patent, issued in February 2016 (No. 9,254,821) is for C- or U-shaped TuffGrip handles used with any size or shape of SafetyTech pad.

“DICA’s SafetyTech products are designed to be strong and unbreakable, delivering the consistent engineered performance that our customers and their crews rely on every day. We are very happy to have received this new patent, which is reflective of the thinking, design and engineering our team puts into every DICA product,” said Kris Koberg, CEO.

The TuffGrip handle system was introduced in 2011 to help improve the long term durability of DICA outrigger pad products and provide an increased level of ergonomic safety for operators handling SafetyTech outrigger pads. Handle length is a small but important example of the innovative thinking in DICA’s TuffGrip handle design. Handle length is specifically designed to encourage proper lifting that requires bending and lifting with the legs.

www.dicausa.com

Knowledge is Your Competitive Edge

A line of comprehensive print and digital learning resources are available for services as well as seasoned professionals. These industry-leading materials cover such topics as basic principles, industry standards, and the latest industrial processes and technologies.

These materials are available in all work environments.

ATP TECHNICAL PUBLICATIONS
www.atp.com

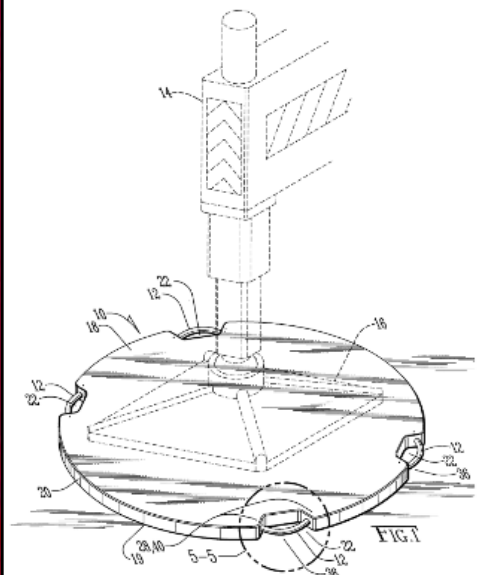

Larson Electronics Announces the Release of a Portable Power Distribution System- 220 Volts AC to 120 Volts AC

Larson Electronics, a longtime leader in commercial and industrial grade lighting equipment, has announced the release of a portable power distribution system that converts 220 volts AC electrical current to 120 volts AC.

The MGL-220V-10KVA-120V-1X120.25A-1X120.35A portable power distribution system from Larson Electronics provides a safe and reliable way for operators in industrial settings to tap into and utilize power sources independently of the work area. This system provides operators the ability to safely tap into and distribute 220 volts AC power from a variety of sources including generators and direct grid power. The transformer is designed to operate with 220 volts, single phase which is then stepped down to single phase 120 volts AC. Two-hundred feet of Type W line-in power cord is included to connect the substation to a primary 220 volt single phase power supply.

On the primary side, a 60-amp disconnect fused with two 60-amp time delay fuses provides the primary line-in protection and supplies the primary power to the 10 KVA transformer. The secondary current is wired to a 120 volt, single phase 80-amp load center with a main breaker for circuit protection.

www.larsonelectronics.com •



RAYCO

PURPOSE BUILT FORESTRY MOWER/MULCHER 99 HP KUBOTA
TURBO DIESEL ENGINE SUPER FLOW, CLOSED LOOP HYDROSTATIC CUTTER HEAD DRIVE
RAYCO-EXCLUSIVE ELEVATED COOLING DESIGN **17.7-INCH RUBBER TRACKS**
2-SPEED TRAVEL EASILY REMOVABLE DEBRIS SCREENS TO PROTECT COOLERS
HYDRAULIC REAR WINCH CAB WITH HEAT AND A/C RAYCO-EXCLUSIVE FORESTRY DOOR
WITH 1.25-INCH LEXAN ESCAPE HATCHES IN ROOFTOP AND REAR WINDOW PREDATOR
MULCHER HEAD WITH VARIABLE DISPLACEMENT HYDRAULIC MOTOR
SEE YOUR DEALER OR CALL 1-800-392.2686

CALL - 800.392.2686 VISIT - RAYCOMFB.COM



Smart Utility Systems Launches Smart Customer Mobile Express

Smart Utility Systems (SUS) is pleased to announce the launch of Smart Customer Mobile (SCM[®]) Express, the market's most rapidly deployable, cloud-based, mobile utility customer engagement platform tailored to support small-to-mid-sized utilities, municipalities and cooperatives. As the compact version of SCM[®], the #1 customer engagement platform for energy and utility companies, SCM[®] Express offers many of the same award-winning, cost-saving features and is simple to implement. In addition to real-time, two-way communication with customers, the single integrated platform offers the most intuitive user interface available, while providing superior backend data analytics to deliver more valuable insights to today's utilities.

"We are proud to offer our newest mobile platform to assist electric, water and gas utilities, particularly at a time when concerns regarding energy efficiency and conservation of Earth's natural resources have reached a critical mass," says Deepak Garg, chairman and CEO of SUS, a leading provider of cloud-based solutions focused on customer engagement and operational efficiency.

www.smartusys.com

BLUE STRIPE Heavy Duty Telescopic Hot Stick

Utility Solutions, Inc. has introduced a BLUE STRIPE[®] Heavy Duty Telescopic Hot Stick that is reported to be stronger than the competition.

Hot line workers using load break tools or operating heavy switches will often exceed the design limitations (pushing, pulling, or twisting) of standard telescopic sticks. Utility Solutions, Inc. specifically designed their new Heavy Duty Telescopic Stick for such applications.

All BLUE STRIPE[®] Telescopic sticks use an epoxy resin and feature a unique non-woven fiberglass construction process which creates a smooth durable surface that resists water absorption. The patented BLUE STRIPE[®] feature takes the hassle out of lining up buttons.

www.utilityolutionsinc.com

CLEANMOTION
4401 WYOMING

PANTHER CARRIERS

Suited for your industry.

- ✓ Innovative chassis design provides easy implement installation
- ✓ Improved ROPS certification allows optimal payload
- ✓ State-of-the-art cab design provides comfort and visibility
- ✓ CLEAN MOTION: the first Panther carrier line-up in the industry
- ✓ 40 percent roller technology provides up to 20% in fuel savings

EUFMC
WILLIAMSBURG, VA
EST. 1954

Learn how PRINCE's tracked carrier line-up is best suited for your industry. Contact us to find the cleanest and most efficient carrier fleet at the EUFMC, June 8-8, 2016 in Williamsburg, VA.

PRINCE Ltd. - North America
www.prince.com | Tel: 401.399.3000



WE KNOW WHAT'S AT STAKE.

For over 100 years, MSA has built a legacy of safety product innovation and reliability by protecting generations of lives in dangerous workplaces. That tradition continues with our full line of personal protective equipment, so your team remains compliant to safety standards which ensures a safe work environment.

Learn more about MSA's complete line of safety solutions or request a General Safety Evaluation by visiting MSAsafety.com, keyword: **safety eval**.



V-Gard[™]
Protective Helmet



ALTIAR[™] 4X
Multigas Detector



Workman[®]
Harness



MSA Latchways
Mini PFL

MSA
The Safety Company

Company	Pg.	Website
Albarrie	29	www.albarrie.com
Amerex	40	www.amerex-fire.com
American Technical Publishers	36	www.atplearning.com
American Pipe & Plastics	17	www.ampipe.com
Buccaneer Rope	8	www.bucrope.com
California Turbo	30	www.californiaturbo.com
CFA Software	35	www.cfsoftware.com
Clearspan	14	www.clearspan.com
Elk River	35	www.elkriver.com
EZ Stak	31	www.ezstak.com
EUFMC	32	www.eufmc.com
GPS Insight	1FC	www.gpsinsight.com
Geny Hitch	15	www.genyhitch.com
Golight	27	www.golight.com
Greaves	18	www.greaves-usa.com
Hastings Fiberglass	9	www.hfgp.com
Herculock	6	www.herculock.com
Hogg & Davis	3	www.hoggdavis.com
iToolco	26	www.itoolco.com
Krenz Vent	2	www.krenzvent.com
Larson Electronics	7	www.larsonelectronics.com
Lineward	35	www.lineward.com
Miller Safety Systems	21	www.millersafetyltd.com
MSA Safety	39	www.msasafety.com
Morooka	34	www.morookacarriers.com
Nesco	BC	www.nescorentals.com
Palfinger	IBC	www.palfinger.com
Precision Sales & Service	19	www.alternatefuel.com
Powerbully	33	www.powerbully.com
Power Gripz	22	www.thepowergripz.com
Prinoth	38	www.prinoth.com
Rayco	37	www.rayco.com
Ring Power	23	www.ringpower.com
Shawmut Tools	4, 5	www.shawmutequipment.com
Time Versalift	1	www.versalift.com
TSE	10	www.tse-international.com
Venco Venturo	11	www.venturo.com



Amerex Corporation
 P.O. Box 81 • Trussville, AL 35173
 Ph: (205) 666-3271 • Fax: 800-864-5980
 email: sales@amerex-fire.com
 www.amerex-fire.com

"Quality is Behind the Diamond"



ISO 9001 & 14001
 OHSAS 18001
 CERTIFIED

EXTINGUISHERS AND FIRE SYSTEMS

INDUSTRIAL • RESTAURANT • MINING • UTILITY • FACILITY
 WASTE MANAGEMENT • FORESTRY • AGRICULTURE
 SERVER ROOM • TELECOMMUNICATION • AIRCRAFT
 AIRPORT • CONSTRUCTION • OFF-SHORE PLATFORM
 REFINERY • TRANSIT BUS • MANUFACTURING
 VESSEL • MILITARY VEHICLE...MORE!



Designed and Assembled in the USA!



P 650 i HIGH INSULATED ACCESS PLATFORM



INSULATED WASHER

PALFINGER's insulated washer cleans all types of insulators and porcelain insulators with the integrated high-pressure water spray. It's the most effective way to clean your insulators.



HIGHLY EFFICIENT

A fully automated control system allows the operator to adjust the platform's height, width, and rotation. The platform's automatic control system ensures that the platform is always in the correct position for the job.



EASY AND SAFE HANDLING

The P 650 i platform is designed for easy and safe handling. The platform's compact design and low weight make it easy to transport and store. The platform's automatic control system ensures that the platform is always in the correct position for the job.

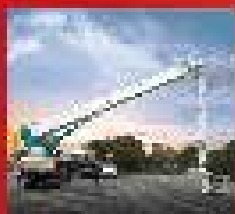

COMPACT AND FLEXIBLE

The P 650 i platform is designed for compact and flexible use. The platform's compact design and low weight make it easy to transport and store. The platform's automatic control system ensures that the platform is always in the correct position for the job.

PALFINGER

LIFETIME EXCELLENCE

SEE IT AT ICGEE
BOOTH L-315

For more information, visit our website at www.palfinger.com or call us at 1-800-368-7263. We are a leading manufacturer of aerial work platforms, including scissor lifts, boom lifts, and truck-mounted aerial lifts. Our products are designed for safety, efficiency, and reliability. We are committed to providing the highest quality products and services to our customers.

WWW.PALFINGER.COM

NESCO

SUPERIOR

**CUSTOMER
SERVICE**

RESPONSIVENESS AND SUPPORT SECOND TO NONE

NESCO Rentals® isn't just a premier provider of utility rental equipment, but a leader in responsiveness and support for all customers. Dedicated rental and service teams, combined with one of the industry's largest rental fleets, ensure NESCO meets your job site needs. Call us now to experience our superior customer service.



Visit our website, build a quote, outfit your vehicles and get to work.

(800) 252-0043 | www.nesco rentals.com

